

Grinder - CDD 2.5/3.0 Channel Monster™ - Open channel series

SULZER

The CDD 2.5/3.0 Channel Monster protects pumps and other sensitive equipment by capturing and grinding the toughest wastewater solids in high-flow, heavy solids loading systems. It utilizes two rotating drums to capture solids and direct them to a powerful, dual-shafted, slow-speed, high-torque grinder designed to shred the tough solids that typically cause sewer problems.

Construction

- Open channel configuration
- Grinder cutter stack heights from 1'000 mm to 2'250 mm
- Hardened alloy steel cutters (standard), 191 mm and 222 mm diameter
- Ductile iron housings
- Stainless steel drums with 12.7 mm perforations available in 250 mm, 400 mm or 500 mm diameters
- Hardened alloy steel shafts, 64 mm and 76 mm hex
- Mechanical seals with tungsten carbide faces, 10.3 bar maximum dry working pressure
- Available with channel or wall mounted frame options for easy installation

Performance

- Flow rates up to 9'305 m³/hr

Applications

- Pump stations
- Collection systems
- Headworks at wastewater treatment
- Private facility discharge to municipal sewer system
- Prison sewage system protection

Monster Renew grinder

In place of repairing a worn grinder, choose a Monster Renew unit. Sulzer provides a new, factory-built grinder cartridge to replace the worn grinder cartridge. Remove the motor and reducer from the worn unit, install the motor and reducer on the Monster Renew unit, and install the new assembly in place of the worn unit. Benefits include:

- Minimizes operational downtime
- Quick turnaround
- All new parts
- Great time to upgrade unit
- Full factory warranty on the Monster Renew grinder cartridge



Channel Monster motor assembly

- Single-drive system with 7.5 kW or 11 kW motor powers grinder stack and drums
- Optional multidrive system with one motor to drive grinder stack (7.5 kW or 11 kW) and individual motors for each drum (0.75 kW)
- Optional explosion proof and immersible motors available
- 35:1 reducer, cycloidal design

Channel Monster frame options

- Adapt grinders for easy installation
- Channel frames to fit most channel types
- Wall frames to mount on flat or round walls
- Type 304 or 316 stainless steel construction
- Guide rails for easy installation and maintenance

Channel Monster controller

- Ensures maximum grinding ability with minimum stoppage
- Designed and programmed for specified motor

Channel Monster grinder cutters

Tooth count	Thickness	Material
7-tooth	11 mm	Hardened alloy steel
11-tooth	8 mm	Hardened alloy steel

Channel Monster grinder materials

Part	Standard
Housings	Ductile Iron
Cutters	Hardened alloy steel
Drums	Stainless steel
Shafts	Hardened alloy steel
Mechanical seals	Tungsten carbide faces
Gaskets	Viton™

For guidance in selecting a CDD Channel Monster, please contact Sulzer.

Performance curves

Model CDD 2.5 with 250 mm Drums

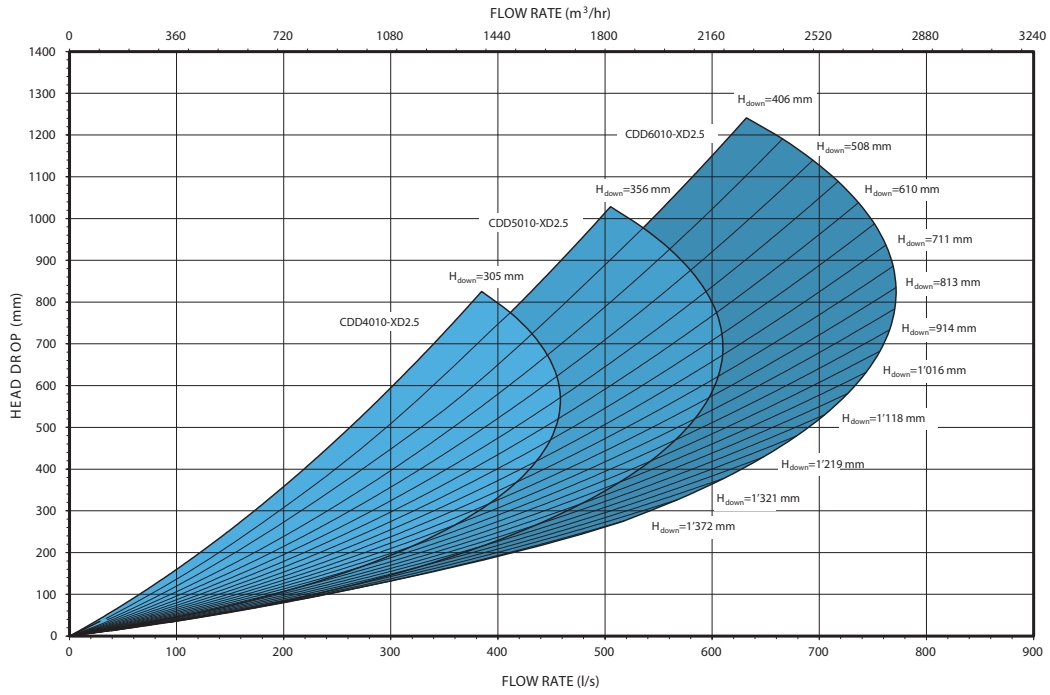

Model CDD 2.5 with 400 mm Drums

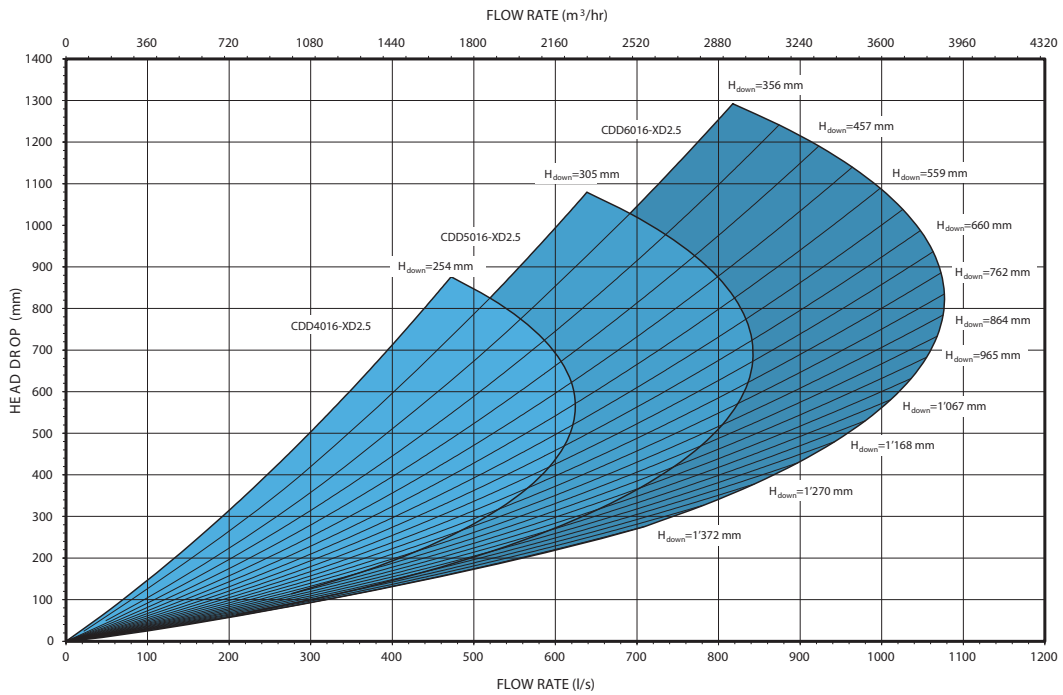

mm = head drop
 m³/hr = capacity (raw sewage)
 H_{down} = downstream head

Performance curves

Model CDD 2.5 with 500 mm Drums

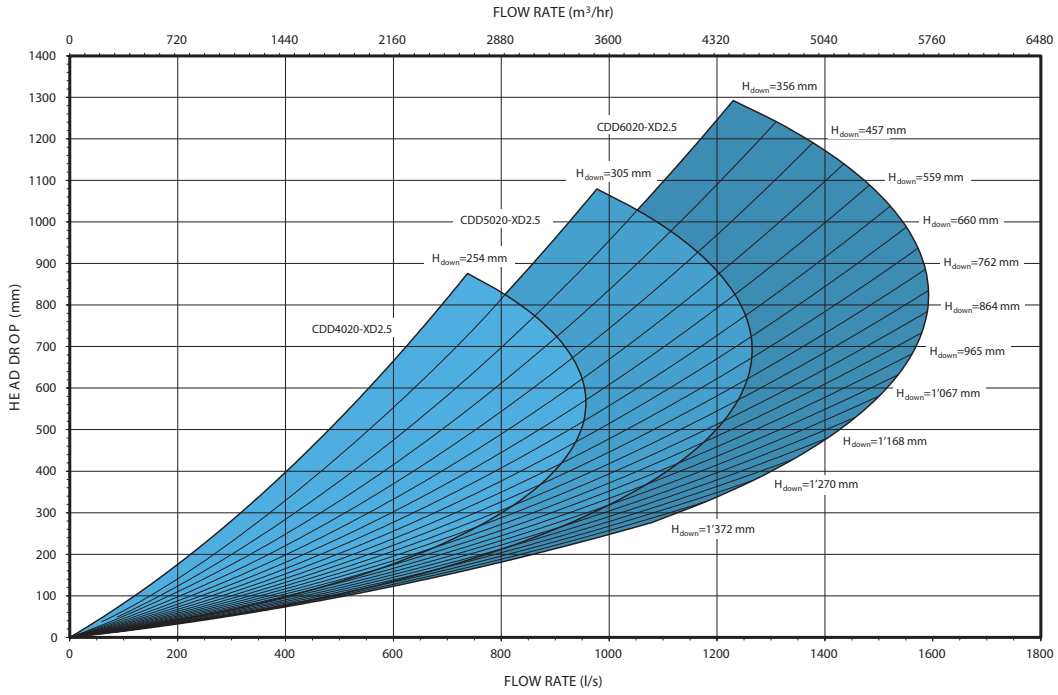

Model CDD 3.0 with 500 mm Drums

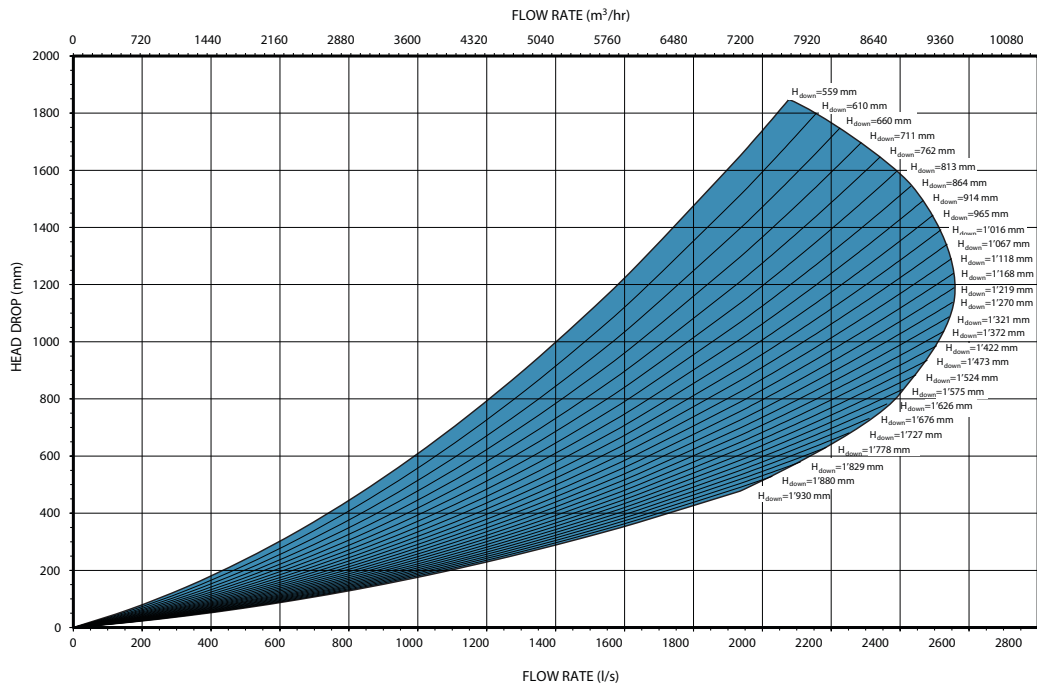

mm = head drop
 m³/hr = capacity (raw sewage)
 H_{down} = downstream head

Dimensions (mm)

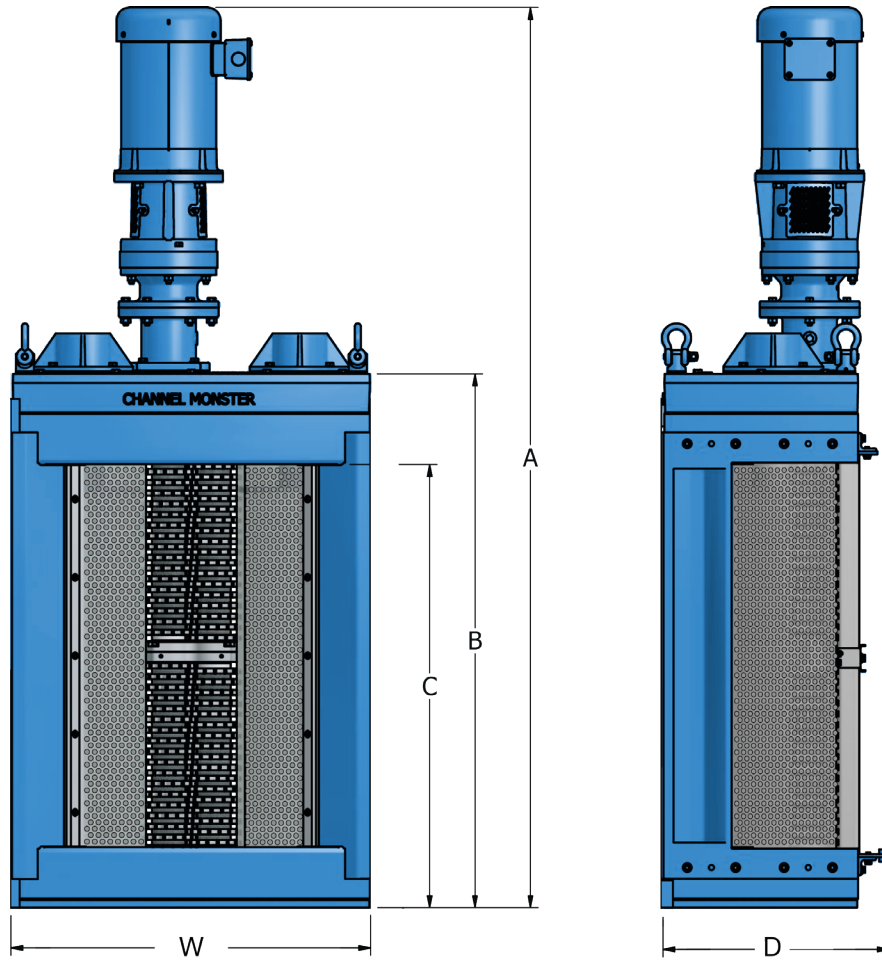

Single-drive version shown

Dual drum model	Drum size - mm	B - mm	C - mm	D - mm	W ¹ - mm	Max flow ² - m ³ /hr	Single drive		Multidrive	
							A ³ - mm	Approximate net weight ⁴ - kg	A ³ - mm	Approximate net weight ⁴ - kg
CDD4010-XD2.5	250	1'449	1'168	681	749	1'650	2'558	1'870	2'558	1'919
CDD5010-XD2.5	250	1'695	1'416	681	749	2'195	2'804	1'960	2'804	2'009
CDD6010-XD2.5	250	1'965	1'686	681	749	2'778	3'074	2'074	3'074	2'123
CDD4016-XD2.5	400	1'449	1'168	900	1'060	2'247	2'538	2'210	2'538	2'259
CDD5016-XD2.5	400	1'695	1'416	900	1'060	3'030	2'784	2'323	2'784	2'372
CDD6016-XD2.5	400	1'965	1'686	900	1'060	3'876	3'054	2'459	3'054	2'508
CDD4020-XD2.5	500	1'449	1'168	719	1'365	3'443	2'538	2'505	2'538	2'554
CDD5020-XD2.5	500	1'695	1'416	719	1'365	4'549	2'784	2'630	2'784	2'679
CDD6020-XD2.5	500	1'965	1'686	719	1'365	5'729	3'054	2'777	3'054	2'826
CDD9020-XD3.0	500	2'875	2'486	908	1'365	9'305	Not Available		3'988	4'666

1. For ideal channel construction width add 50 mm.

2. Flow based on optimum channel conditions. Consult factory for analysis of application.

3. Drive dimensions are a maximum based on a unit with a 7.5 kW (IP68) motor. Extended drive shafts are available on request.

4. Weight is based on a unit with a 7.5 kW IP68 drive.

CDD 2.5/3.0 Channel Monster grinder model coding

Product family	Solids reduction sewage grinder	Q																		
Grinder family	CDD 2.5 double drum Channel Monster	E																		
	CDD 3.0 double drum Channel Monster	F																		
Grinder configuration	New unit with motor (specified separately)		2																	
	Monster Renew unit		E																	
	Monster Renew unit with spool		F																	
Cutter stack height	1'000 mm (40 inch)			R																
	1'250 mm (50 inch)			T																
	1'500 mm (60 inch)			W																
	2'250 mm (90 inch)			Y																
Flange information	Not applicable				X	X														
Cutter material	Alloy steel							1												
Cutter	7-tooth, 11 mm thick								C	4										
	11-tooth, 8 mm thick								F	3										
Body material & colour	Cast iron blue										S									
Seals & gaskets material	Severe duty seals & Viton gaskets											V								
Drum diameter	250 mm (10 inches)																		1	
	400 mm (16 inch)																		3	
	500 mm (20 inches)																		5	
Drum information	12.7 mm perforated, 304L stainless steel																			B
Drive configuration	Single drive																			S
	Multidrive																			M

Example: CDD5020-XDM2.5 new unit with 1'250 mm cutter stack, 7-tooth (11 mm) alloy steel cutters, severe duty seals & Viton gaskets, 500 mm drums, and multidrive **Q E 2 T X X 1 C 4 S V 5 B M**

Channel Monster motor assembly

Power	Voltage	Protection type	Description	Motor model code
7.5 kW	400V, 3-phase, 50 Hz	IP55 (standard)	Grinder motor	QF1435B2R
7.5 kW	400V, 3-phase, 50 Hz	IP55 for ATEX (Ex d IIC T4)	Grinder motor	QF2435B2R
7.5 kW	400V, 3-phase, 50 Hz	IP68 for ATEX (Ex de IIB T4)	Grinder motor	QF3435B1R
11.0 kW	400V, 3-phase, 50 Hz	IP55 (standard)	Grinder motor	QG1435B2R
11.0 kW	400V, 3-phase, 50 Hz	IP55 for ATEX (Ex d IIC T4)	Grinder motor	QG2435B1R
11.0 kW	400V, 3-phase, 50 Hz	IP68 for ATEX (Ex de IIB T4)	Grinder motor	QG3435B1R
0.75 kW	400V, 3-phase, 50 Hz	IP55 (standard)	Drum motor	QN1435B2Y
0.75 kW	400V, 3-phase, 50 Hz	IP55 for ATEX (Ex d IIC T4)	Drum motor	QN2435B2Y
0.75 kW	400V, 3-phase, 50 Hz	IP68 for ATEX (Ex de IIB T4)	Drum motor	QN3435B2Y

Channel Monster controller

Grinder motor type	Model code for IP65 control panel enclosure		
	Description	Power coated mild steel material	Stainless steel material
7.5 kW IP55	Single drive	QN1P45XXX	QN1S45XXX
7.5 kW IP68	Single drive	QN2P45XXX	QN2S45XXX
7.5 kW IP55	Multidrive	QN1P45TXX	QN1S45TXX
7.5 kW IP68	Multidrive	QN2P45TXX	QN2S45TXX
11.0 kW IP55	Multidrive	QP1P45TXX	QP1S45TXX
11.0 kW IP68	Multidrive	QP2P45TXX	QP2S45TXX